



VESTIL MANUFACTURING CORP.

2999 North Wayne Street, P.O. Box 507, Angola, IN 46703

Telephone: (260) 665-7586 -or- Toll Free (800) 348-0868

Fax: (260) 665-1339

www.vestilmfg.com e-mail: sales@vestil.com

CYL-H Series Cylinder Storage Cabinets

Assembly and Maintenance Manual

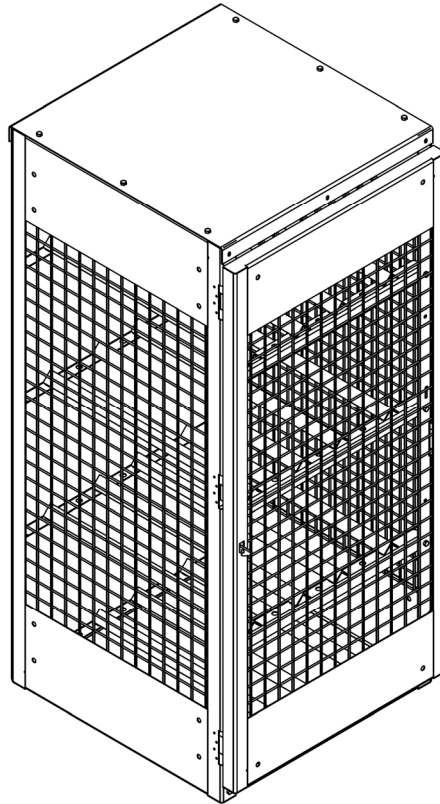

Receiving instructions:

After delivery, IMMEDIATELY remove the packaging from the product in a manner that preserves the packaging; then inspect the product closely to determine whether it sustained damage during transport. **If damage is discovered during the inspection, immediately record a complete description of the damage on the bill of lading.** If the product is undamaged, discard the packaging.

NOTES:

- 1) Compliance with laws, regulations, codes, and non-voluntary standards enforced in the location where the product is used is exclusively the responsibility of the owner/end-user.
- 2) VESTIL is **not liable** for any injury or property damage that occurs as a consequence of failing to apply either:
 - a) Instructions in this manual; or
 - b) Information provided on labels affixed to the product. Neither is Vestil responsible for *any* consequential damages sustained as a result of failing to exercise sound judgment while assembling, installing, using or maintaining this product.

Table of Contents

Product Specifications.....	2 - 3
Signal Words.....	3
Safety Recommendations.....	3
Anchor cabinet to the ground.....	4
Loading the cabinet.....	4
Inspections & Maintenance.....	4
Label Placement Diagram.....	4
Limited Warranty.....	5

Product specifications: Dimensions and other product specifications appear in the following table based on the following diagrams.

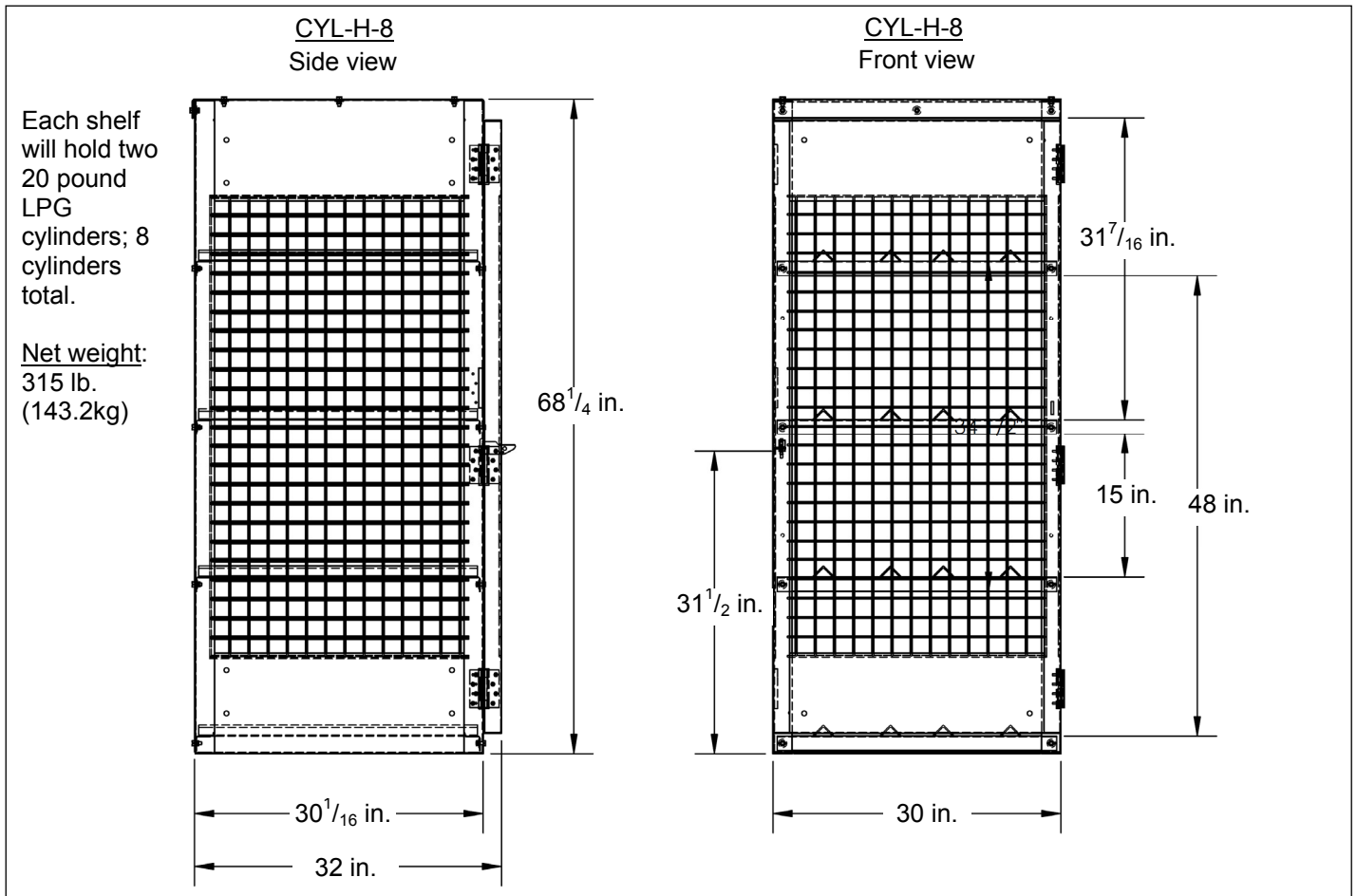
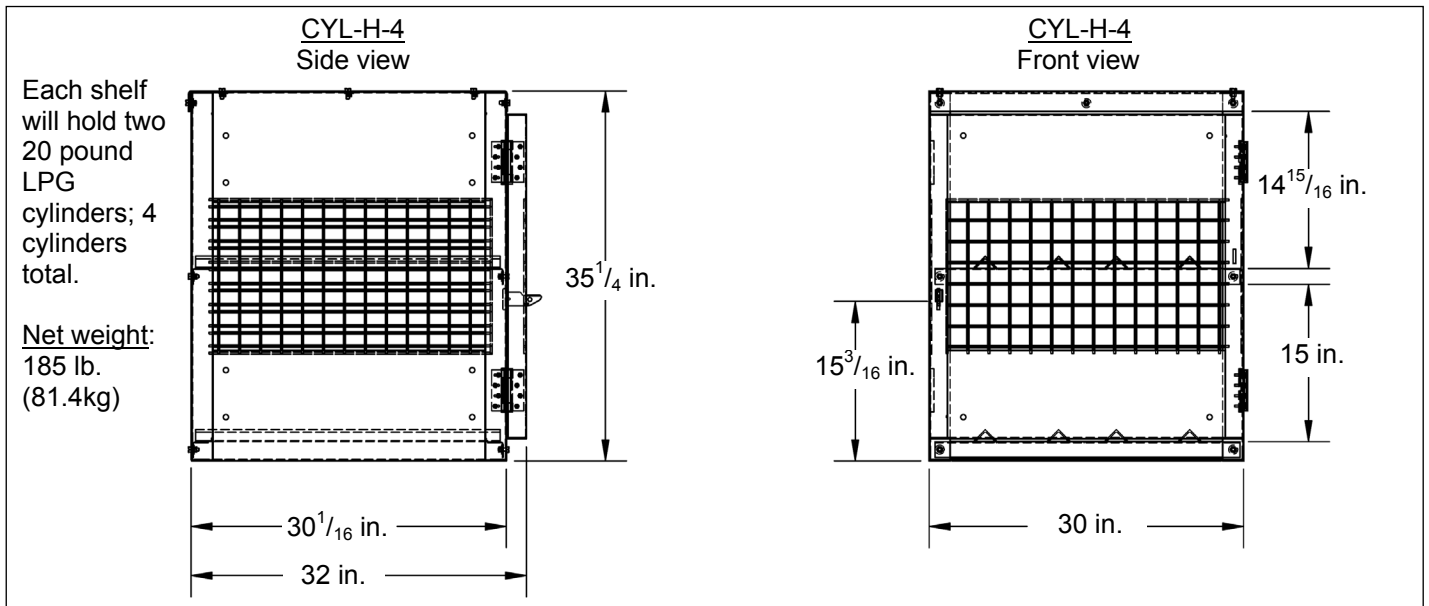

Model	# of 20 lb. LPG tanks	Overall Dimensions (W x L x H)	Net weight
CYL-H-4	2 per shelf (4 tanks total)	30in.in. x 32in. x 35 ¹ / ₄ in.	185.0 lb. 84.1 kg
CYL-H-8	2 per shelf (8 tanks total)	30in.in. x 31 ¹³ / ₁₆ in. x 68 ¹ / ₄ in.	315 lb. 143.2 kg
CYL-H-16	2 per shelf (16 tanks total)	60in. x 32in. x 68 ¹ / ₄ in.	487.1 lb. 221.4 kg

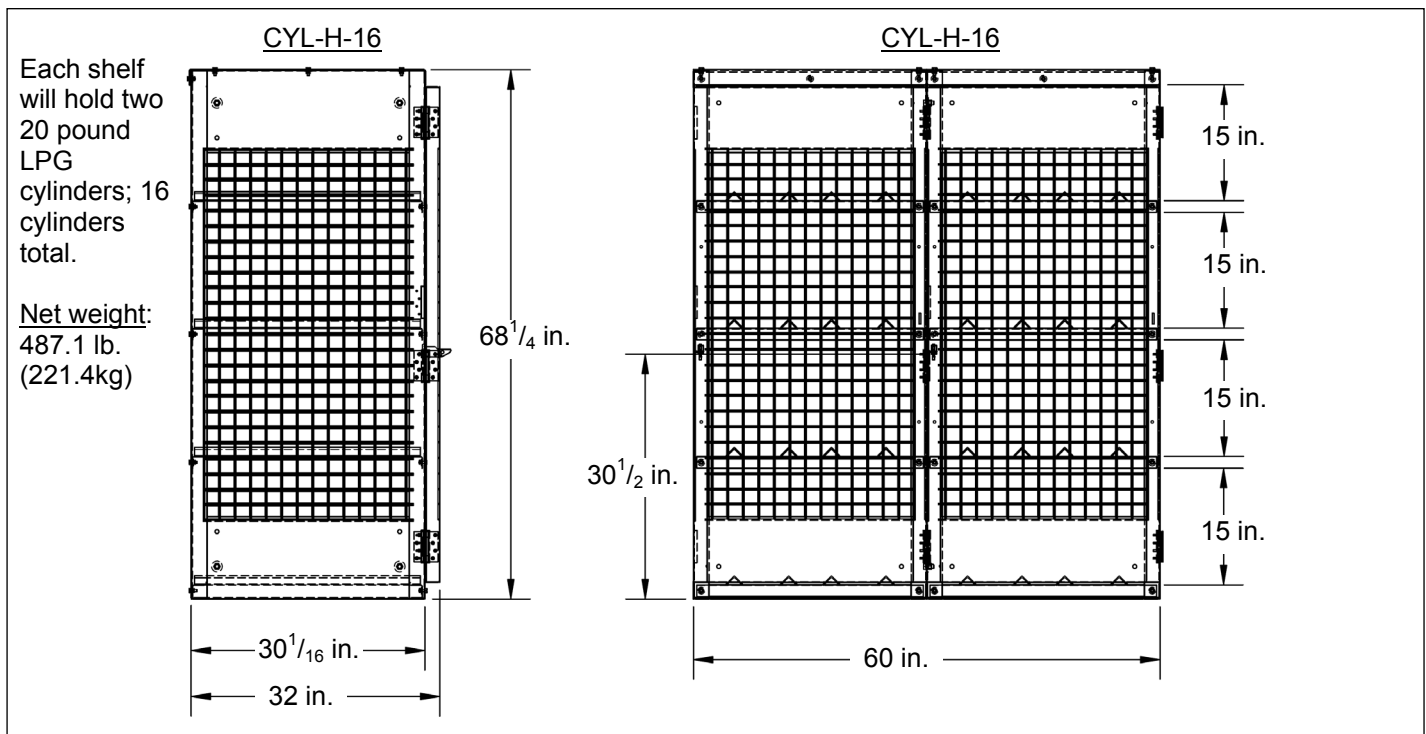

SIGNAL WORDS:

This manual uses SIGNAL WORDS to indicate the likelihood of personal injuries, as well as the probable seriousness of those injuries, if the product is misused in the ways described. Other signal words call attention to uses of the product likely cause property damage. The signal words used appear below along with the meaning of each word:



Identifies a hazardous situation which, if not avoided, WILL result in DEATH or SERIOUS INJURY. Use of this signal word is limited to the most extreme situations.



Identifies a hazardous situation which, if not avoided, COULD result in DEATH or SERIOUS INJURY.



Indicates a hazardous situation which, if not avoided, COULD result in MINOR or MODERATE injury.



Identifies practices likely to result in product/property damage, such as operation that might damage the product.

Each person who assembles, installs, uses, or maintains this product should read the entire manual in advance and fully understand the directions.

Safety Recommendations:

We strive to identify foreseeable hazards associated with the use of our products. However, no manual can address every risk. The end-user ultimately is responsible for exercising sound judgment at all times.



Failure to properly store liquefied petroleum gases ("LPG" or "LP-Gas") might lead to serious personal injuries.

- Always apply proper cylinder handling techniques learned during training.
- **Failure to read and understand the entire manual before assembling, using or servicing the product constitutes misuse.** Read the manual to refresh your understanding of proper use and maintenance procedures as necessary.
- Inspect the cabinet regularly; DO NOT use it unless it is in normal condition. (See "Maintenance & Inspections" recommendations on page 4.)
- DO NOT use the cabinet if a shelf is damaged. Immediately tag the unit "Out of Service". Complete repairs/replacements before using the cabinet again.
- DO NOT modify this product in any way. Modifications automatically void the limited warranty and might make the cabinet unsafe to use.
- DO NOT install the cabinet in a location where water pools. Standing water might damage the bottom of the cabinet and make it unstable.
- DO NOT use the cabinet UNLESS all labels are in place and readable (see "Label placement diagram" on p. 4).

Anchor the cabinet to the ground:

Place the cabinet in the desired location; then mark the ground with the locations of all 4 bolt slots in the base plate of the cabinet (see FIG. 1 which shows a cutaway view of the right side of a CYL-H). A bolt slot is present in each corner of the base plate. The slots will accept 1/4in. (diameter) anchor bolts. Your building engineer should select anchor bolts of appropriate length. Anchor the cabinet to the ground before loading the shelves.

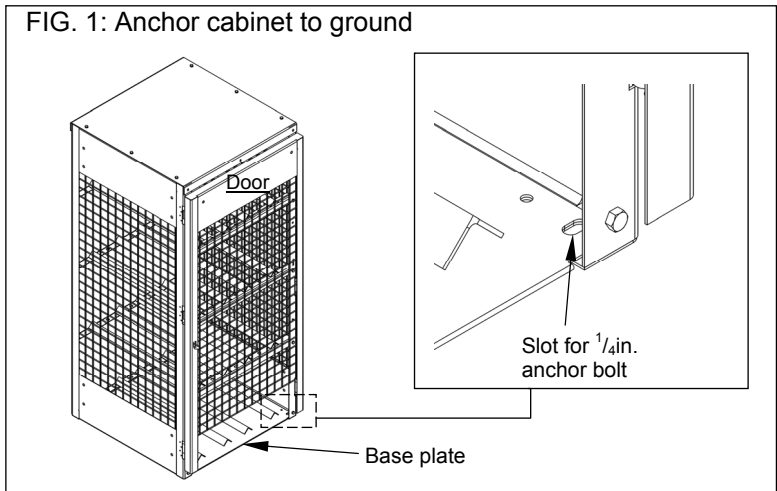

Loading the cabinet:

Each shelf will hold 2 standard 20 lb. LPG cylinders stored upright.

Inspections & Maintenance:

⚠️WARNING DO NOT use the cabinet to store LPG cylinders if the shelves or frame are structurally unsound. **If a problem is discovered during an inspection, restore the cabinet to normal operating condition BEFORE using it again.** If you notice structural damage, immediately remove all cylinders from the cabinet, tag it "Out of Service", and report the problem to maintenance personnel.

Inspect the cabinet at least once per month:

- i) Inspect the cabinet for structural soundness. The structure should be solid a square. Check for bends, warps, cracks, etc.
- ii) Check for corrosion/rust, particularly where the paint is damaged. Remove rust with a steel bristle brush (or sandpaper); then apply touchup paint or clear finish to the affected area.
- iii) Apply grease to any hinge that squeaks or grinds when the door is opened or closed.
- iv) Inspect the shelves: check for bends, warps, & cracks. Remove rust and reseal wherever necessary.

Label placement diagram:

The cabinet should be labeled as shown below. Contact Vestil to order replacement labels.

Label 287: Model & capacity
(apply to inside of door; cover with 770)

MODEL/MODELO/MODELE	_____
STATIC CAPACITY (evenly distributed)	_____ lbs.
LA CAPACIDAD CONSTANTE (distribuida uniformemente)	_____ kgs.
CAPACITÉ STATIQUE (distribuée régulièrement)	_____ kgs.
SERIAL/SERIE/SÉRIE	_____

287 REV 0812

Label 203:

Label 735: FLAMMABLE – NO SMOKING

Label 204: Secure frame to floor (apply to frame below door)

⚠️WARNING	⚠️ADVERTENCIA	⚠️AVERTISSEMENT
SECURE FRAME TO FLOOR	ASEGURE EL BASTIDOR AL PISO	FIXER SOLIDEMENT LE CADRE AU PLANCHER

204 Rev 11/15

LIMITED WARRANTY

Vestil Manufacturing Corporation (“Vestil”) warrants this Semi-Automatic Strapping Machine, model S-2001 to be free of defects in material and workmanship during the warranty period. *Our warranty obligation is to provide a replacement for a defective original part if the part is covered by the warranty, after we receive a proper request from the warrantee (you) for warranty service.*

Who may request service?

Only a warrantee may request service. *You are a warrantee if* you purchased the product from Vestil or from an authorized distributor AND Vestil has been fully paid.

What is an “original part”?

An original part is a part used to make the product as shipped to the warrantee.

What is a “proper request”?

A request for warranty service is proper if Vestil receives: 1) a photocopy of the Customer Invoice that displays the shipping date; AND 2) a written request for warranty service including your name and phone number. Send requests by any of the following methods:

<u>Mail</u>	<u>Fax</u>	<u>Email</u>
Vestil Manufacturing Corporation 2999 North Wayne Street, PO Box 507 Angola, IN 46703	(260) 665-1339 <u>Phone</u> (260) 665-7586	sales@vestil.com

In the written request, list the parts believed to be defective and include the address where replacements should be delivered.

What is covered under the warranty?

After Vestil receives your request for warranty service, an authorized representative will contact you to determine whether your claim is covered by the warranty. Before providing warranty service, Vestil may require you to send the entire product, or just the defective part or parts, to its facility in Angola, IN. The warranty covers defects in the following original dynamic components: motors, hydraulic pumps, electronic controllers, switches and cylinders. It also covers defects in original parts that wear under normal usage conditions (“wearing parts”), such as bearings, hoses, wheels, seals, brushes, and batteries.

How long is the warranty period?

The warranty period for original dynamic components is 90 days. For wearing parts, the warranty period is 90 days. The warranty periods begin on the date when Vestil ships the product to the warrantee. If the product was purchased from an authorized distributor, the periods begin when the distributor ships the product. Vestil may, at its sole discretion, extend the warranty periods for products shipped from authorized distributors by up to 30 days to account for shipping time.

If a defective part is covered by the warranty, what will Vestil do to correct the problem?

Vestil will provide an appropriate replacement for any covered part. An authorized representative of Vestil will contact you to discuss your claim.

What is not covered by the warranty?

1. Labor;
2. Freight;
3. Occurrence of any of the following, which automatically voids the warranty:
 - Product misuse;
 - Negligent operation or repair;
 - Corrosion or use in corrosive conditions;
 - Inadequate or improper maintenance;
 - Damage sustained during shipping;
 - Accidents involving the product;
 - Unauthorized modifications: DO NOT modify the product IN ANY WAY without first receiving written authorization from Vestil. Modification(s) might make the product unsafe to use or might cause excessive and/or abnormal wear.

Do any other warranties apply to the product?

Vestil Manufacturing Corp. makes no other express warranties. All implied warranties are disclaimed to the extent allowed by law. Any implied warranty not disclaimed is limited in scope to the terms of this

